

## **Recommendation**

Linnet power & bus installation.doc

Linnet power and bus installation practices

122.10.2007

### ***Overview***

Following chapters presents guidelines for making Linnet installations reliable and easy to maintain. These rules of thumb, in fact, should be considered with any installations, not just with Linnet networks. These recommendations are presented in two sections: first one presenting Linnet bus installation guidelines and the second one recommended powering rules.

### **Recommendations for Linet bus installations**

#### **Cable types**

Two types of cables can be used for Linet bus: CAT5 and CAT6 cables, both as unshielded versions (UTP). CAT6 cable is preferred. Shielded cables must NOT be used as their extra capacitance reduce installation range.

In CAT6 or CAT5 cables there are normally 4 twisted pairs in one cable (2 or 3 pairs are far less common). User can use the extra pairs for other purposes. The picture below shows the usage of these cable pairs.

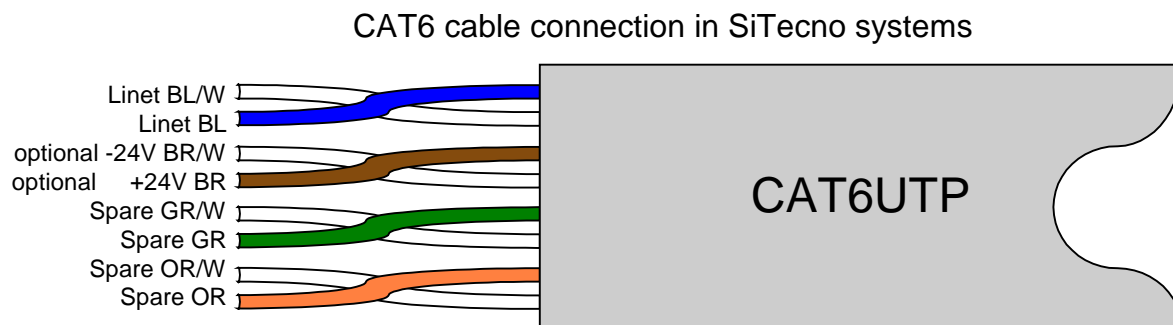
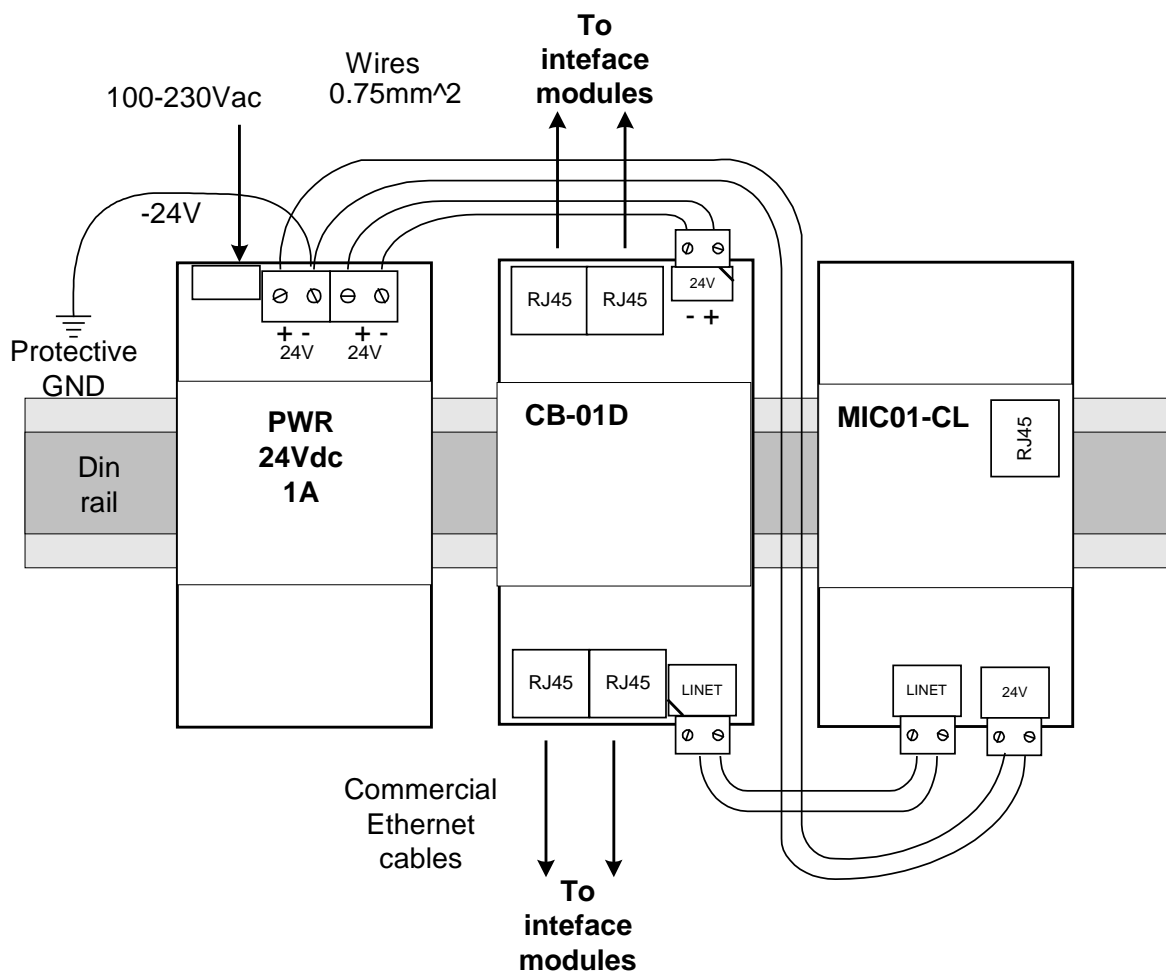

Figure 1. **Cable pair usage.**

### Branching

Although Linnet is topology free, it is highly recommended branching Linnet bus to several segments. Branching will make installation and maintenance much easier. Problems can be easily isolated to smaller area without disturbing rest of the network by unplugging single branches. Unplugging could be effectively used e.g. locating short-circuits in the installation phase – just unplugging the segments until the problem disappears. Figure 2 present recommended arrangement having the first branching as close to Linnet controller as possible.



**Figure 2.** Recommended branching approach (CB-01D) close to the MIC controller.

For branching use either our connection boxes CB-01D and CB-01F or telecommunication Krone-cable connectors

## Recommendation

### Node / module branching

It is a good practice to connect the interface nodes / modules to the network with a separate branch from the main bus segment like on the Figure 3. This way the node can be unplugged from the network without disturbing other nodes.

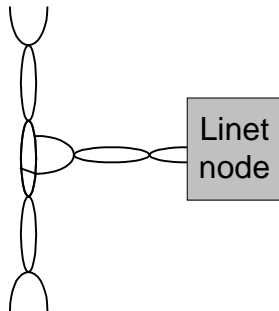

**Figure 3.** Branching on bus  
**Good practice**

If the bus goes through the node connector like on Figure 4, disconnecting that node will cause disturbance to the other nodes behind this node.

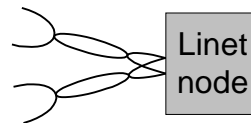

**Figure 4.** Branching on node  
**Bad practice**

### Node count and segment length

Total length behind one Linnet controller (all the segments added together) MUST NOT exceed 1000 meters. Also due to the resistive signal damping only a limited number of nodes per bus segment length is allowed. See the graph on the Figure 5 to determine the maximum limits per segment.

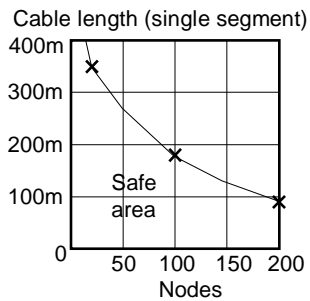
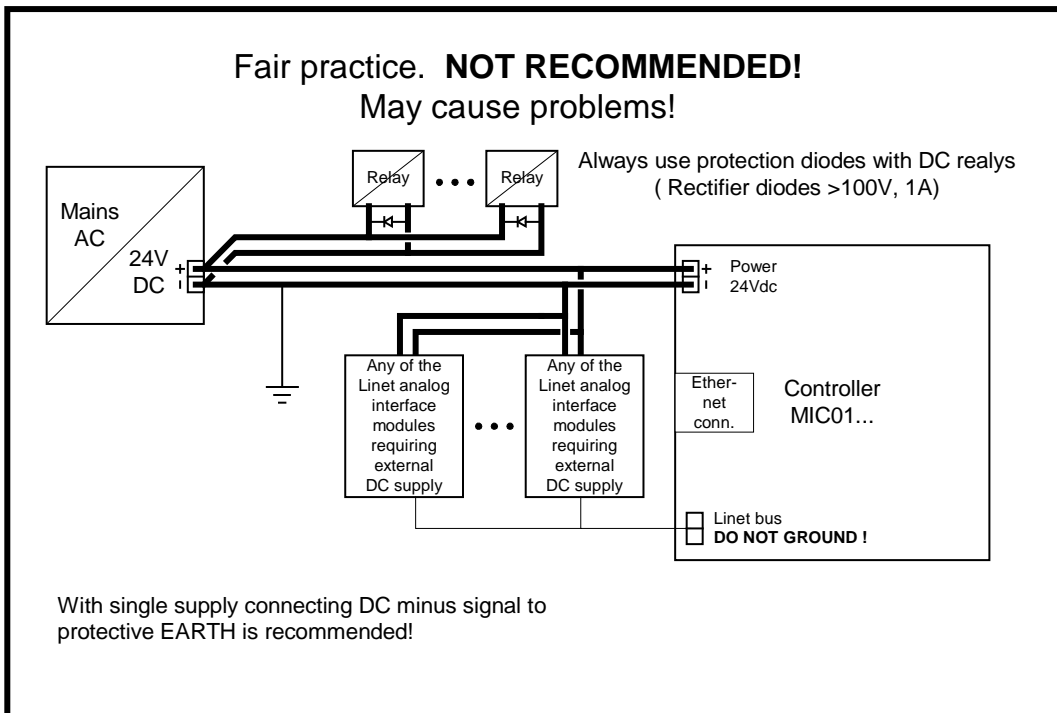
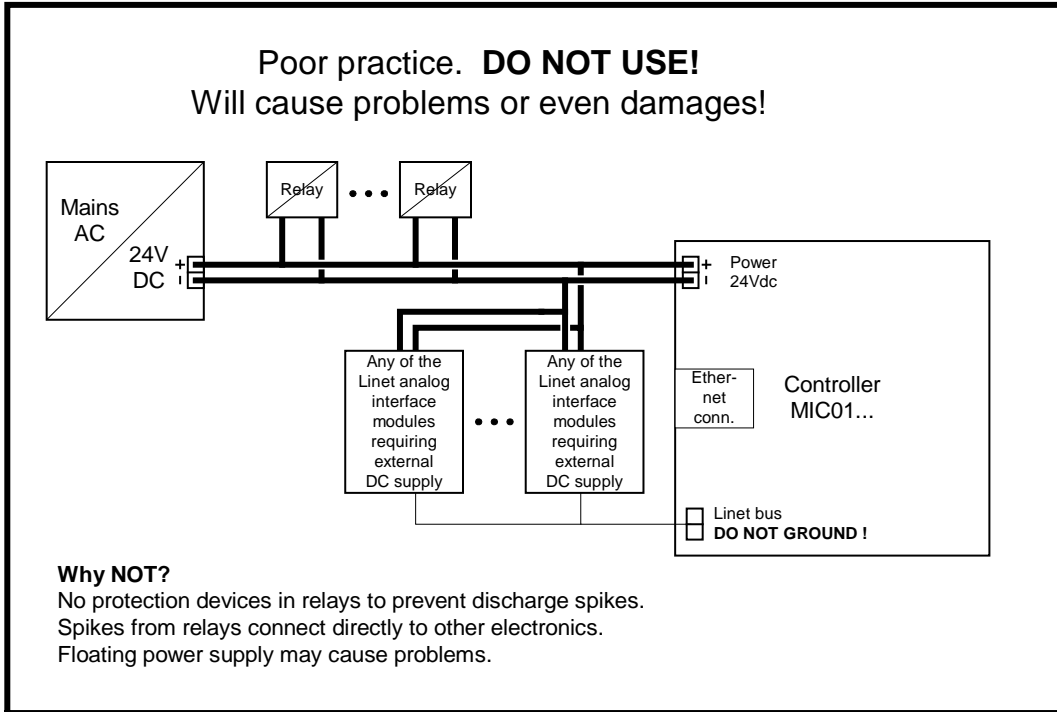

**Figure 5.** Maximum node count corresponding to segment length.

### ***Recommendations for power feed with Linnet bus installations***

Linnet bus can provide power together with the data. In addition to this power limited to 10 mW for each Linnet node some devices may need more power. Following self explaining figures present the guidelines how power should be fed without producing noise coupling and electrical problems.

## Recommendation



## Recommendation

